

# USER'S MANUAL

---

## AIRVENTS AV S



AIR HANDLING UNIT

---

**CONTENTS**

Safety requirements.....	3
Purpose.....	4
Designation key.....	4
Design.....	5
Installation and set-up.....	8
Connection to power supply.....	11
Start-up preparations.....	13
Automation.....	14
Test run .....	14
Operation and maintenance.....	14
Control measurements of operating parameters .....	19
Storage and transportation rules.....	20
Manufacturer's warranty.....	21
Certificate of acceptance.....	23
Seller information.....	23
Installation certificate.....	23
Warranty card.....	23

This user's manual is a main operating document intended for technical, maintenance, and operating staff.

The manual contains information about purpose, technical details, operating principle, design, and installation of the AIRVENTS AV S unit and all its modifications.

Technical and maintenance staff must have theoretical and practical training in the field of ventilation systems and should be able to work in accordance with workplace safety rules as well as construction norms and standards applicable in the territory of the country.

## SAFETY REQUIREMENTS

All operations described in this manual must be performed by qualified personnel only, properly trained and qualified to install, make electrical connections and maintain ventilation units.

Do not attempt to install the product, connect it to the mains, or perform maintenance yourself. This is unsafe and impossible without special knowledge.

Disconnect the power supply prior to any operations with the unit.

All user's manual requirements as well as the provisions of all the applicable local and national construction, electrical, and technical norms and standards must be observed when installing and operating the unit.

Disconnect the unit from the power supply prior to any connection, servicing, maintenance, and repair operations.

Connection of the unit to power mains is allowed by a qualified electrician with a work permit for the electric units up to 1000 V after careful reading of the present user's manual.

Check the unit for any visible damage of the impeller, the casing, and the grille before starting installation. The casing internals must be free of any foreign objects that can damage the impeller blades.

While mounting the unit, avoid compression of the casing! Deformation of the casing may result in motor jam and excessive noise.

Misuse of the unit and any unauthorised modifications are not allowed.

Do not expose the unit to adverse atmospheric agents (rain, sun, etc.).

Transported air must not contain any dust or other solid impurities, sticky substances, or fibrous materials.

Do not use the unit in a hazardous or explosive environment containing spirits, gasoline, insecticides, etc.

Do not close or block the intake or extract vents in order to ensure the efficient air flow.

Do not sit on the unit and do not put objects on it.

The information in this user's manual was correct at the time of the document's preparation.

The Company reserves the right to modify the technical characteristics, design, or configuration of its products at any time in order to incorporate the latest technological developments.

Never touch the unit with wet or damp hands.

Never touch the unit when barefoot.

**BEFORE INSTALLING ADDITIONAL EXTERNAL DEVICES, READ THE RELEVANT USER MANUALS.**

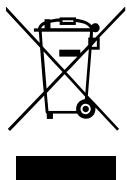

**THE PRODUCT MUST BE DISPOSED SEPARATELY AT THE END OF ITS SERVICE LIFE.**

**DO NOT DISPOSE THE UNIT AS UNSORTED DOMESTIC WASTE**

## PURPOSE

The unit consists of a number of connectable assembly units with various design to enable numerous composition options for various air handling processes.

The unit is designed for air conditioning, ventilation with heat recovery, air heating, cooling, dehumidification or humidification, depending on available functioning components.

The air capacity ranges from 1000 up to 18 200 m<sup>3</sup>/h. The air handling unit is designed for ventilation of residential, commercial, industrial building, trade centres, exhibition halls, etc.

**Each air handling unit is designed individually for a customized ventilation network. No warranty for full-featured operation of the unit in case of its use in a ventilation network possessing other parameters than the rated ones.**

The unit is rated for continuous operation.

Transported air must not contain any flammable or explosive mixtures, evaporation of chemicals, sticky substances, fibrous materials, coarse dust, soot and oil particles or environments favourable for the formation of hazardous substances (toxic substances, dust, pathogenic germs).



**THE UNIT SHOULD NOT BE OPERATED BY CHILDREN OR PERSONS WITH REDUCED PHYSICAL, MENTAL, OR SENSORY CAPACITIES, OR THOSE WITHOUT THE APPROPRIATE TRAINING.**

**THE UNIT MUST BE INSTALLED AND CONNECTED ONLY BY PROPERLY QUALIFIED PERSONNEL AFTER THE APPROPRIATE BRIEFING.**

**THE CHOICE OF UNIT INSTALLATION LOCATION MUST PREVENT UNAUTHORISED ACCESS BY UNATTENDED CHILDREN.**

## DESIGNATION KEY

### CASING SIZE

AV S\_\_\_\_\_

Nominal air capacity m<sup>3</sup>/h x 1000

### SILENCER TYPE

SRI

Insulated silencer

—

Without silencer

### PREHEATER SECTION

pHE

Electric with built-in filter

pHW

Water with built-in filter

—

Without preheating function

### CONFIGURATION TYPE

R2VFV(H)

FV(V)R1FV(V)

R2M2VFV(H)

R2MVFV(H)

FV(V)CFFV(V)

FV(V)CFMFV(V)

CF1V

CF2VFV(H)

CFMFV(H)

### Configuration components

V — fan

FV(V) — fan + filtration section  
(connected vertically)

FV(H) — fan + filtration section  
(connected horizontally)

### Heat exchanger type

R2 — rotary with built-in supply filter	R1 — rotary	R2M2 — rotary with built-in supply filter and recirculation	R2M — rotary with built-in supply filter and mixing chamber
CF — plate counterflow	CF1 — plate counterflow with built-in filters	CF2 — plate counterflow with built-in supply filters	CFM — plate counterflow with recirculation

### HEATER TYPE

HE	HW	—
Electric heater	Water heater	Without heater

### COOLER TYPE

CDX	CW	—
Freon cooler	Water cooler	Without cooler

### SERVICE SIDE

L	R
Left	Right

### CONTROL PANEL

—	A__	A__
None	Kvent with a panel	Other variants of the automation system

\_\_\* — rated capacity

## DESIGN

The unit consists of a number of blocks enclosed in a casing, made of rigidly fixed heat- and sound-insulated panels, 50 mm thick, made of galvanized steel or aluzinc and filled with mineral wool. Extra structural stability may be attained due to use of a mounting frame made of rolled steel.

The automation and control system enables operation of the air handling units for air conditioning with the set parameters and controls the air handling processes for each type of the unit configuration.

The outdoor modification of the unit is designed for mounting and operation outside of the building, under the roof. The air handling unit must be equipped with a drain pipe to protect the unit against atmospheric precipitation. The drain pipe is equipped with a fine mesh to prevent ingress of mechanic objects up to 10 mm in size.

The unit design is regularly improved, so some models may slightly differ from those ones described herein.

## SECTIONS

### Ventilation section

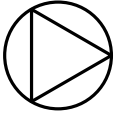

Fans with EC motors and FanGrid modules are used with the number of fans from 1 to 8 for each side (supply and exhaust).

### Heat recovery section

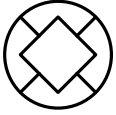

The heat exchanger plates are sealed with an elastic thermal sealant and are locked with each other. Sealing of the heat exchanger plates ensures partition of the air streams in the heat exchanger.

The heat recovery section may be equipped with a droplet separator to prevent drifting of condensed water drops with air streams. A droplet separator consists of multiple-folded plastic plates.

The water drops are separated because of frequent air direction changes and are accumulated in the plate bends.

The water drops are accumulated on the impeller blades and then are drained to the drain pan.

Applied for the air handling units with the internal air velocity above 2.5 m/s to prevent drifting of condensed water drops in the air ducts.



The rotary heat exchanger section consists of a heat wheel driven by electric motor belts. The rotary heat exchanger is made of aluminium band and has a cellular structure. The brush sealing around the heat wheel serves to minimize air backflow.

The rotary heat exchanger is available with a fixed or controllable rotation speed.

An integrated electronic speed controller ensures smooth speed control and maintaining the optimal temperature mode.

### Electric heater section

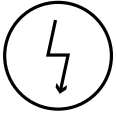

An electric heater is used for supply air reheating. Extra fins of the heating elements enlarge the heat exchange area. The electric heater has two overheat protection thermostats.

### Water heater section

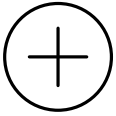

A water heater is used for supply air reheating. Hot water or ethylene glycol solution with max. operating temperature 150 °C are used as a heat medium. Connection of the water heaters to the heating network may be performed with threaded, flanged or welded joints. The water heater may be equipped with temperature gauge taps enabling installation of an automatic freeze protection system.

### Cooling section

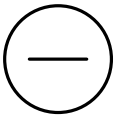

The units may comprise a water or DX cooler to reduce the supply air temperature. Cold water, ethylene glycol solution or Freon gas are used as a heat medium.

The heat recovery section may be equipped with a droplet separator to prevent drifting of condensed water drops with air streams. A droplet separator consists of multiple-folded plastic plates. The water drops are separated because of frequent air direction changes and are accumulated in the plate bends. The water drops are accumulated on the impeller blades and then are drained to the drain pan.

Applied for the air handling units with the internal air velocity above 2.5 m/s to prevent drifting of condensed water drops in the air ducts.

### Filter section



The filters enable filtration of supply and exhaust air streams and prevent contamination of heat exchangers and automation units as well as filter clogging. Coarse filters ensure first step filtration of the air stream prior to subjecting it to the more efficient fine filters (allows to extend the service life of the main filter).

The integrated coarse and fine filters ensure high-quality air filtration of supply air. The filters may be of panel and pocket-type with a metal or plastic frame design.

A panel filter has a compact design. The low installation depth of the filter ensures efficient internal space utilisation. The filter has low air resistance and a long service life. The filter has low aerodynamic drag and a long service life.

A pocket filter has a special pocket-like shape. Thus, it is featured with a large filtering surface and outstanding dust capability. The filter has an extended service life and low maintenance costs. The filter consists of series of filtering cells ranging from the G3 to the F9 class according to the EN 779 standard (coarse and fine filter).

The quality and long service life of the filters in the course of the unit operation are ensured by easy access to the filters for clogging control as well as their convenient cleaning and replacement.

### Silencer

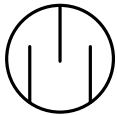

The plate silencers serve for attenuating the noise generated by the unit and auxiliary equipment during operation. The silencer consists of galvanized steel plates internally filled with a sound absorbing fire-resisting insulation material, extra protected with a synthetic fiber. The noise absorbing plates have a special coating to protect the sound-absorbing material.

### Air mixing section

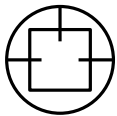

The air mixing section enables mixing of supply and exhaust air streams. Regulation of ratio of the air streams is performed with manual or automatic air dampers.

### Inspection section

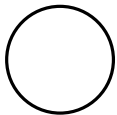

An inspection section is a casing with an inspection door. This section is installed between components requiring inspection and maintenance. The inspection section is used in cases when any of the air handling unit components must be subjected to regular measurements. The section may be equipped with an inspection window and internal lighting for additional convenience.

The empty section is installed between the air handling unit sections to contain sensors (i.e. temperature sensor) and to enable subsequent replacement with a different section of the air handling unit.

### Air damper

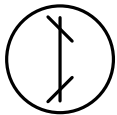

The air damper is designed for automatic shutoff of the air duct during the system shutoff. The air dampers of the air handling units are rated Class 3 for air tightness according to the EN 1751 standard. The dampers contain counter-rotating aluminium shutters with high aerodynamic performance.

The shutters may be equipped with extra cold proof heat insulation for extreme temperature conditions. Smooth air flow control is ensured by means of the gear drive made of robust heat-resistant plastic. The damper operation is controlled by means of the spring-return electric drive for guaranteed locking of the damper shutters in the closed position in case of an emergency power outage.

### Flexible connector

Flexible connector is designed to cut off vibration transmission from the fans to the air ducts and to partially compensate for the air duct assembly deformations caused by temperature variation.

The flexible connectors consist of two flanges connected with vibration-absorbing material. The vibration connector is not intended to withstand any significant mechanical loads and, therefore, may not be used as load-bearing structures.

**INSTALLATION AND SET-UP**

**READ THE USER'S MANUAL BEFORE INSTALLING THE UNIT.**



**ALL OPERATIONS DESCRIBED IN THIS USER'S MANUAL MUST BE PERFORMED BY QUALIFIED PERSONNEL ONLY, PROPERLY TRAINED AND QUALIFIED TO INSTALL AND MAINTAIN VENTILATION EQUIPMENT.**

**DO NOT ATTEMPT TO INSTALL THE PRODUCT YOURSELF. IT IS UNSAFE AND IMPOSSIBLE WITHOUT SPECIAL KNOWLEDGE.**

The units are available in the left-hand and right-hand modifications to enable maintenance access on either the left or the right side. The maintenance side is marked depending on its position relative to the direction of air supply to the premises. The maintenance side determines the position of the heater (cooler) fittings and condensate drain pipes.

AIRVENTS AV S ... L

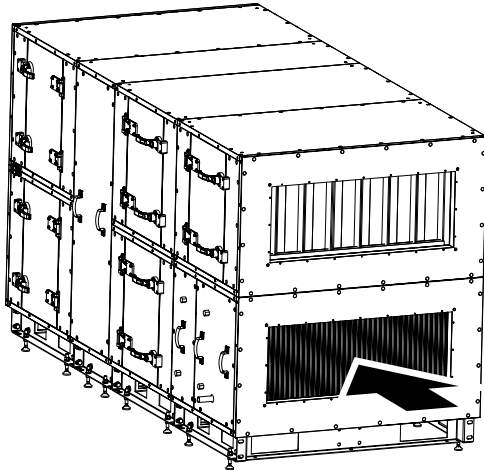

AIRVENTS AV S ... R

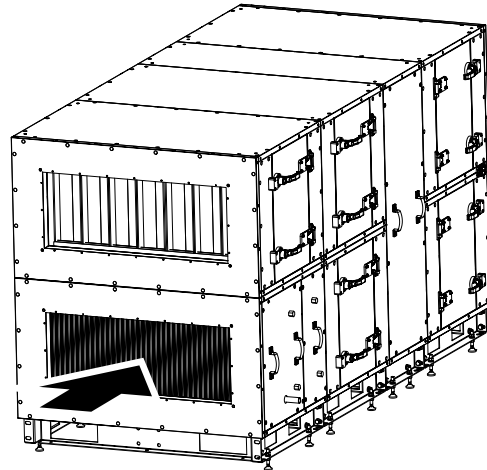



Read carefully the Safety Requirements regulations prior to assembly of the air handling unit (page 2).

Check all the unit sections for mechanical damages.

Check the unit for completeness.

The unit must be mounted to a smooth hard surface. The quality and stability of the surface intended for the unit installation must be verified by a duly qualified person.

It is essential to place the unit above the mounting deck level. The frame and the levelling feet enable unit mounting at an elevation of up to 180 mm. If the U-trap height exceeds the maximum mounting elevation (see the calculation table below), the unit must be mounted above the deck level to create the clearance required for the U-trap installation.

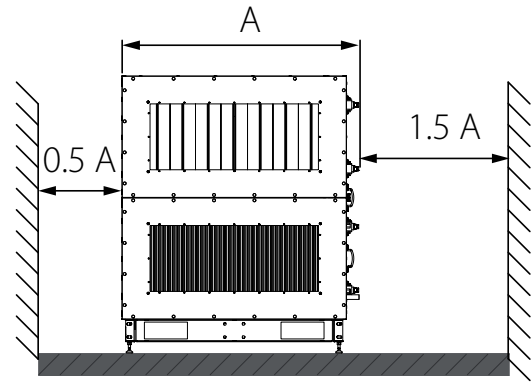

### Installation on a frame with a levelling feet

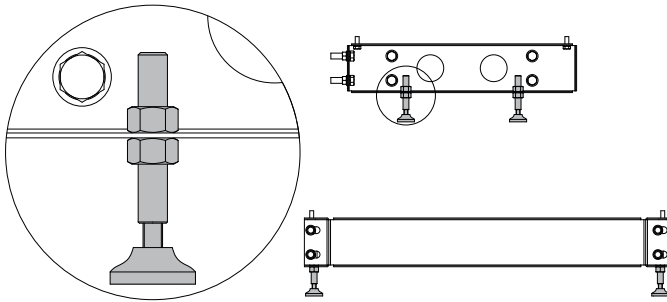

### Installation on brackets with a levelling feet

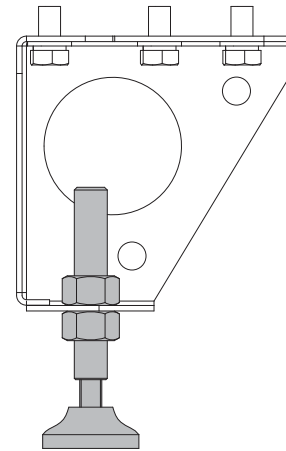

### Connection of the unit sections

The unit sections are bolted and may be installed on a mounting frame if required. The piled sections are interconnected with a coupling bracket.

Each of the unit sections is uniquely marked to ensure convenience of operation and prevent improper installation and maintenance.

**WARNING!**

**Do not connect the unit sections with ratchet tie-down straps!**

The sections are interconnected with M8x60 screws and nuts, washers and wedge lock washers. To connect the unit sections, open the service panels first and tie them up with bolts through fastener holes. The mounting frames of separate sections or levelling feet must also be tied up.

**WARNING!**

**Tightening of the sections start with x-shaped brackets inside the sections!**

**Place nuts on bolts manually to avoid damage of a rivet nut.**

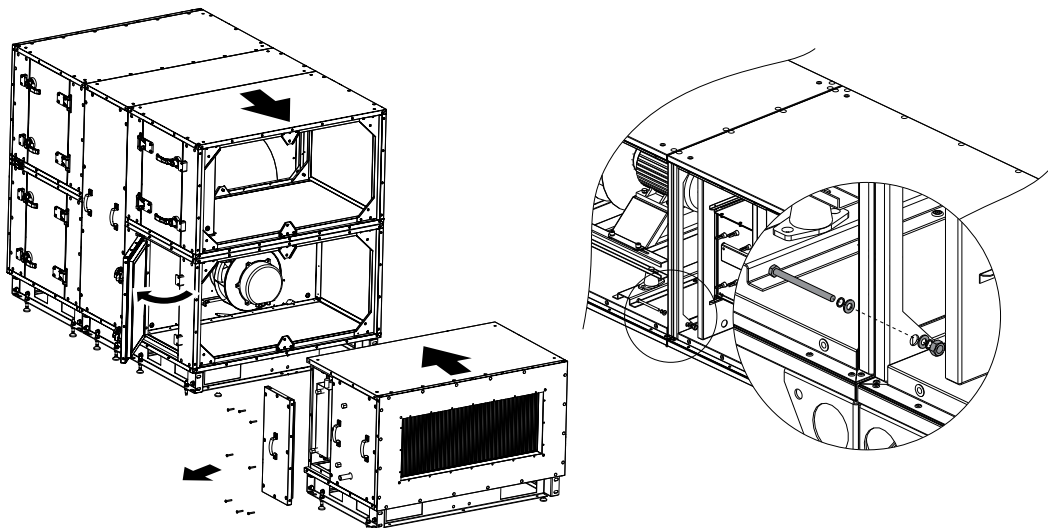

The piled sections are interconnected with coupling brackets and screws, nuts, washers and wedge lock washer. The coupling brackets are installed during mounting of the section.

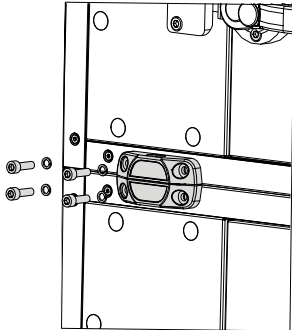

The roof of the units in the outdoor modification which have been delivered in sections must be mounted only after joining the sections.

All the roof joints must be insulated with a joint filler on the inside. Treat the screws with a sealant prior to screwing in to enable good sealing of the joints.

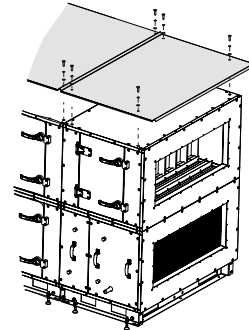

### Connection of air ducts, rainscreen hoods and ducts components to the unit

The air duct must be connected to the units by means of elastic anti-vibration connectors which attenuate the vibrations transmitted by the unit to the air ducts. The anti-vibration connectors also compensate for any misalignment while joining the units with the air ducts. The anti-vibration connectors are bolted to the air ducts. The connected equipment and the air ducts must be equipped with individual fastenings to avoid the transfer of own weight load onto the unit.

### Connection of water heating or cooling sections

Any mounting and wiring operations of the hydraulic system must be performed by qualified technicians only! The circulation pump must be grounded. The power cable must not be in contact with the pipeline or the pump. The hot or cold medium flow direction must be opposite to the air flow.

#### WARNING!

**On connection of a water heater and/or water or dx cooler the length of straight pipeline sections must be at least 400 mm from the unit (as shown below). Any shorter length will prevent opening of the service panels.**

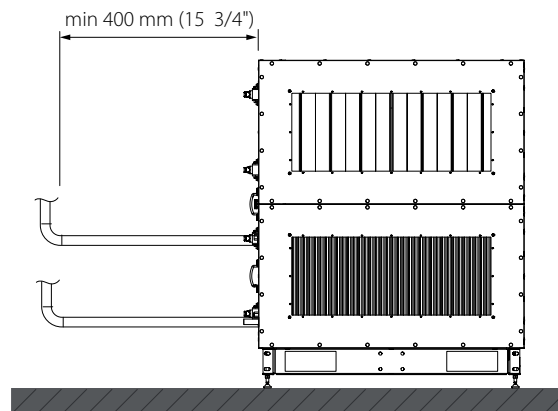

The heater and cooler connections must be subject to zero mechanical loads on the feed pipeline side. The water pressure must remain below 1.5 MPa. It is recommended to use shutoff valves which block the hot or cool water supply in case of an emergency dismantling without draining the heat transfer agent from the equipment.

### CONDENSATE DRAINAGE

The droplet collectors installed in the cooling and heat recovery sections are equipped with drain pipes through which the condensation is removed outside the unit. Connect the U-trap to the outlet pipe. The U-trap and the droplet separator must be equipped with a freeze protection.

The U-trap dimensions depending on the size of the pressure in the section are stated in Table.

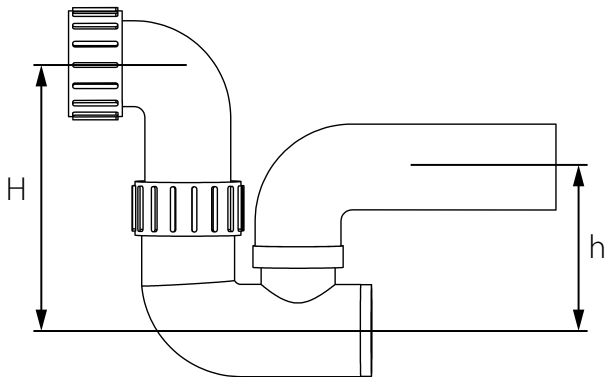

Total Fan Pressure [Pa]	Size H [mm]	Size h [mm]
<600	100	50
600-1000	140	70
1000-1400	190	95
1400-1800	240	120
1800-2200	290	145
2200-2600	340	170

### CONNECTION TO POWER SUPPLY



**THE UNIT CONNECTION TO THE POWER SUPPLY MUST BE PERFORMED BY DULY QUALIFIED PERSONNEL MADE FAMILIAR WITH THE PRESENT OPERATION MANUAL.**

**THE UNIT IS INTENDED FOR CONNECTION TO AC MAINS SUPPLYING THE VOLTAGE COMPLIANT WITH THE TECHNICAL SPECIFICATION CHART. CHECK THE ENTIRE POWER CORD LENGTH FOR CHOKING. DO NOT SWITCH ON THE UNIT IF THE CABLE IS DAMAGED.**

**CHECK THE ENTIRE POWER CORD LENGTH FOR CHOKING.**

**DO NOT SWITCH ON THE UNIT IF THE CABLE IS DAMAGED.**

**DISCONNECT THE UNIT FROM POWER SUPPLY PRIOR TO ANY OPERATIONS.**

**THE RATED ELECTRICAL PARAMETERS OF THE UNIT ARE STATED ON THE RATING PLATE.**

#### WARNING!

**CONNECTION OF THE ELECTRICAL ELEMENTS OF THE PRODUCT MUST BE CARRIED OUT BY APPROPRIATELY QUALIFIED AND AUTHORISED PERSONNEL AND ALSO IN ACCORDANCE WITH THE NORMS AND STANDARDS APPLICABLE IN THE COUNTRY OF INSTALLATION.**

**ELECTRICAL CONNECTIONS MUST NOT COMPROMISE THE TIGHTNESS AND FUNCTIONALITY OF THE PRODUCT.**

**ELECTRICAL CONNECTIONS MUST BE ADAPTED TO THE CONDITIONS AT THE PLACE WHERE THE PRODUCT IS INSTALLED (TEMPERATURE AND HUMIDITY, TYPE OF CABLE LAYING, DISTANCE TO THE SWITCHBOARD, ETC.)**

**THE PRODUCT MUST BE EQUIPPED WITH A CIRCUIT BREAKER.**

**FAILURE TO COMPLY WITH THESE REQUIREMENTS WILL INVALIDATE THE WARRANTY.**

### FAN CONNECTION

All the connections must be made in accordance with the technical specifications for the automatic control system.

The electric power supply must comply with the following specifications:

- Voltage: voltage within 0.9 ...1.1 of the rated value;
- Frequency: 0.99...1.01 of the nominal frequency at all times and 0.98...1.02 at peak times

**EC-motor**

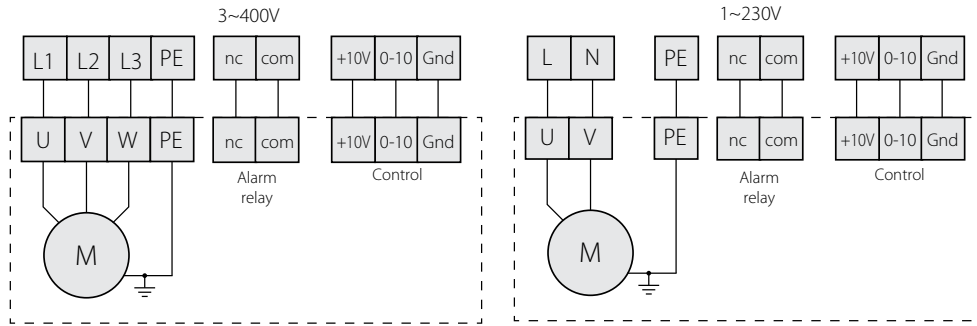

**ELECTRIC HEATER CONNECTION**

The electric heaters are equipped with overheat protection thermostats that are triggered when the 3~400V temperature reaches 50 °C (automatic reset) and 90 °C (manual reset). Wiring of the electric heaters is shown on the diagram on the right.

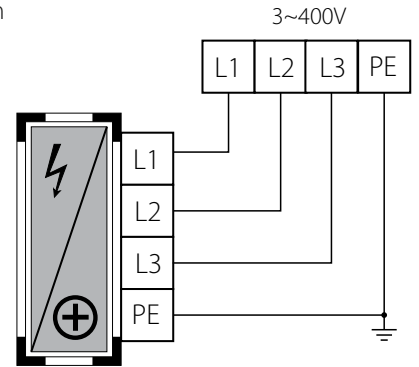

**AIR DAMPER CONNECTION**

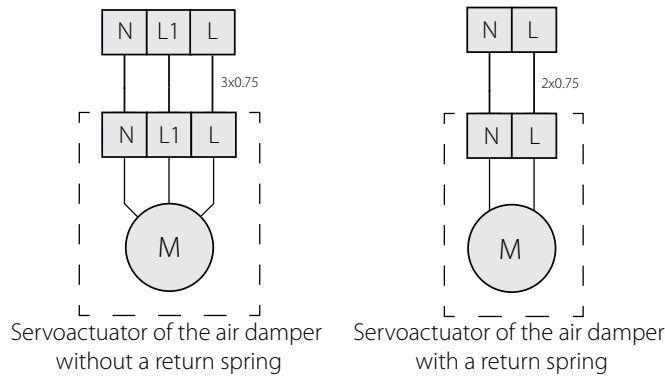

**CONNECTION OF PRESSOSTATS**

The pressostat on the filter must be installed in such a way so that its pipe marked with the (-) symbol is routed via a tube to the lower pressure area (downstream of the filter) whereas the pipe marked with the (+) symbol is routed to the higher pressure area (upstream of the filter).

The pressostat on the fan must be installed in such a way so that its pipe marked with the (-) symbol is routed via a tube to the lower pressure area (upstream of the motor) whereas the pipe marked with the (+) symbol is routed to the higher pressure area (downstream of the motor).

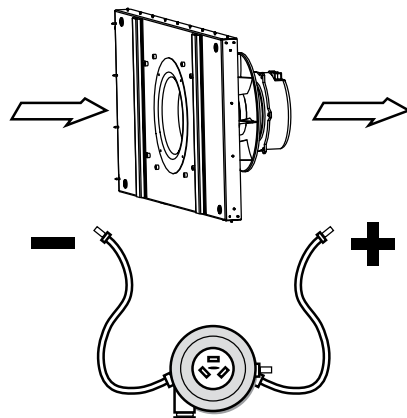
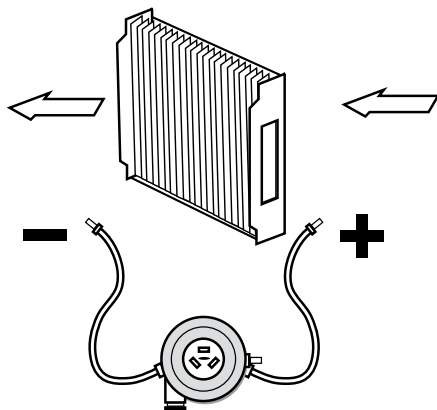

## START-UP PREPARATIONS

The permanent operation must be preceded by start-up preparations. Such a start-up must only be performed by the properly qualified and trained personnel. Prior to the test run the personnel must study the instructions and schematic diagrams being part of the technical documentation of the unit and perform the following steps:

- Check the unit for proper installation.
- Check all the ventilation devices for proper connection to the power supply.
- Make sure all the hydraulic and electrical connections are properly connected to the to the respective sections of the unit.

### **Electrical equipment**

Check the electrical equipment for proper connection, insulation integrity and grounding against the electrical connections diagram and the technical parameters of the components. Further inspect the electric wires and the power consumers visually for insulation integrity. The installation operations must comply with the provisions of the unit-specific technical documentation.

Any non-compliance of the installation work with the technical documentation shall void the manufacturer's warranty for the unit. If the installation has been performed by the manufacturer's engineers, the electrical equipment and the entire unit shall be covered by the identical warranty for the air handling unit.

### **Electric heaters**

Make sure the heater is clean and intact. Connect the heater in accordance with the wiring diagram. The connected heater must not be in contact with other elements of the units.

### **Water heaters**

Check the pipelines for proper connection (supply and return lines) and then inspect the condition of the heater plates. Adjust the settings of the freeze protection thermostat (factory setting +5 °C) in succession as well as the tightness of the capillary contact with the heater surface. The heat medium control valve controlling the heater operation must be installed in accordance with the markings on the casing.

### **DX, water and glycol coolers**

Check the condition of the cooler plates and the supply and return pipelines for proper connection. Then check the droplet separator for proper installation relative to the air flow and then perform the same with regards to the U-trap.

### **Filters**

Check the filters for proper attachment, their density and general condition. The detailed filter specifications shall be checked against their respective documentation.

### **Cross-flow plate heat exchanger**

Check the heat exchanger surface for any contamination and mechanical damage.

Check the droplet separator (if available) for proper installation relative to the air flow, and then perform the same with regards to the U-trap. If the heat exchanger is equipped with a bypass, check the air shutters, dampers and electric actuator mounting.

### **Rotary heat exchanger**

Make sure that the heat exchanger cells are clean and free from damage. Check the belt tension with the spring attached to the motor base and adjust it, if necessary. Check the control unit mount (if available).

### **Fan section**

Check the fan section prior to starting the unit. Make sure that the section is free from any foreign objects such as the yellow-colour transportation fasteners and assembly components. Failure to do so may result in the unit damage. The fan impeller must have a smooth running.

### **Then check the following:**

- The electrical connections against the wiring diagrams;
- The fan motor for proper connection (the mains voltage must comply with that one on the motor rating plate);
- The ground wire for proper connection if the fan is mounted on rubber anti-vibration dampers;
- The rubber anti-vibration dampers in the fan section for proper installation;
- All the wires in the fan section for proper clamping.

If all the above steps are successfully completed, all the unit doors may be closed.

## AUTOMATION

Automation is an integral part of each supplied air handling unit. It enables smooth control and failsafe operation of the unit, prevents possible operation problems and alarms.

This user's manual contains no data or guidelines for mounting of the automation system components, connection, commissioning and operation of the system.

This information is available in the supplied technical documentation for a delivered automation system type. Otherwise the supplier of the automation system must provide the required information.

The control unit may be supplemented with extra controls like air damper actuators, frequency converters, pressure and temperature sensors, CO<sub>2</sub> sensors, constant air flow sensors, humidifiers, triac controllers.

Operation manuals for the automation system components are supplied separately.

## TEST RUN

The unit start-up preparations and the test run must only be performed by specially trained and duly qualified personnel. Prior to starting the fans check the air dampers for proper operation. Correct and safe operation of the unit is provided only in case of connection to designed ductwork system.

After the start-up let the unit run for approximately 30 minutes. During the test operation measure the electrical equipment current and the unit air capacity. Absence of elevated noise levels, abnormal noises or smells generated by the unit or vibration registered during the test run suggests successful commissioning of the air handling unit. If the results suggest otherwise, troubleshoot any malfunctions in the unit operation. On registering any of the above phenomena disconnect the unit from power supply and double-check each of its sections. After the unit power-off and before opening the panels make sure that the unit impeller has come to a full stop. If this cannot be confirmed visually, do not open the panels until 3 minutes after the power-off. If no malfunctions occur within a 30-minute test run the unit can be switched off and inspected.

### **Inspect:**

- The filter mounts;
- Condensate removal efficiency;
- Motor temperature and the condition of the fan group bearings.

Upon checking all the connections check the ant-vibration dampers for proper operation. If allowed by the climatic conditions, check the freeze protection thermostat operation. Such check may be carried out when the supply air temperature is lower than the thermostat temperature threshold. Should this be the case temporarily shut off the heat medium supply to the heater at the supply air temperature of +1..2 °C. Thermostat activation indicates its proper operation.

If the test run is performed during the warm season, check the thermostat operation at the earliest opportunity during the nearest cold season.

## OPERATION AND MAINTENANCE

The air handling units are designed for continuous operation. Therefore, to ensure proper unit performance schedule periodic checks with special attention given to the life-limited parts such as filters and bearings.

Filter replacement and cleaning are not be considered as warranty cases.

The basic technical details required for the regular inspection are given on the technical specification chart provided with each device.

The chart contains the view and dimensions of the essential elements such as filters, heat exchangers, fans and electric motors.

### **Filters**

The air conditioning units are equipped with pocket and panel filters.

Combination and location of the filters depends on functional composition of the unit.

It is essential during filter replacement to use the filter with the identical filtration class.

Filter clogging reduces its capacity and decreases the unit performance. The filter must be replaced if the filter pressure falls below the critical threshold.

Abnormal filter contamination levels may result in an increased air flow rate in the units which may eventually cause filter warping and even fan damage. During the filter replacement the units must be disconnected from power supply.

The coarse filter replacement frequency mainly depends on the air pollution level.

Proper coarse filter operation significantly extends the useful life of the fine filters.

#### Electric terminals

The electric terminals of all the electrical parts of the unit require periodic checking and tightening to prevent contact scorching and equipment malfunction.

#### Water heater

The water heater is equipped with a freeze protection thermostat as standard. On heat medium supply shutoff or in case of an interruption in the unit operation with the ambient air temperature below + 4 °C the heater must be drained of the heat medium (except using the 40 % glycol mixture).

Contamination of the heater surface reduces its performance. Therefore, check the heater plates for contamination. Dust on the heater plates may also contribute to air resistance increase.

Clean the heaters with a vacuum-cleaner on the air supply side, compressed air jet or washing with a mild water solution of neutral detergents non-corrosive for the aluminium plates.

#### Electric heater

The electric heater contains open coils which may accumulate dust during the unit inactivity. An extensive contamination may generate a smell of burned dust or, in the worst-case scenario, a fire upon the subsequent heater start. Check regularly the technical condition and contamination levels of the heaters and electrical connection. Only dry cleaning is allowed.

#### Water cooler

The water cooler maintenance is identical to that of the water heater. In addition check the cooler and droplet separator for any dirt as well as for the condensate drain pipe obstruction. To remove contamination, clean the cooling coils with a mild water solution of a neutral detergent.

#### DX cooler

The operation and maintenance for the DX coolers are identical to those of the water heater and the water cooler. Make sure that the DX cooler is disconnected from power supply before cleaning. Failure to do so may result in an uncontrolled Freon pressure spike and cooling equipment damage.

#### Cross-flow heat exchanger

The heat exchanger maintenance includes checking the plates for contamination and its technical condition. Clean the cross-flow heat exchanger with a vacuum-cleaner, compressed air jet or washing the air ducts with a mild water solution of a neutral detergent non-corrosive to the aluminium surfaces.

Check the droplet separator condition (if available), the condensate drain pan and the condensate removal system. If the heat exchanger is equipped with a bypass air damper, inspect the bypass damper actuator and check the stroke of the damper shutter.

#### Rotary heat exchanger

While performing the rotary heat exchanger maintenance make sure to check the cell condition. The surface must be free from any contaminations or mechanical damage. Check the belt tensioning regulated by the spring mounted to the motor base.

Check the control unit mount (if available). Clean the rotary heat exchanger with a vacuum-cleaner, compressed air jet or washing the air ducts with a mild water solution of a neutral detergent non-corrosive to the aluminium surfaces.

#### Air damper and air shutter

Check the air dampers periodically. The shutters and gears may accumulate dust, grease and other contaminants preventing proper operation of the dampers.

If present, remove contamination with compressed air jet. If such actions fail, subject the damper to a high-pressure wash with a water solution of a detergent non-corrosive to the aluminium surfaces.

### VENTILATION EQUIPMENT MAINTENANCE REGULATION

	Component name	once in a week	once per month	every 6 months	once in a year
1.	<b>Supply filter*:</b>				
	- Inspection of the condition	-	+	-	-
	- Dust removal, compressed air jet	-	(!)	+	-
	- Replacement	-	-	-	+
2.	<b>Supply filter*:</b>				
	- Inspection of the condition	-	+	-	-
	- Dust removal, compressed air jet	-	(!)	+	-
	- Replacement	-	-	-	+

	Component name	once in a week	once per month	every 6 months	once in a year
	<b>Control switchboard:</b>				
	Check-up of communication lines and power cables for integrity	-	+	-	-
	Check-up of terminal connections	-	+	-	-
	Check-up of launch protection equipment	-	+	-	-
3.	Checking controller operation, analysis of error log	+	-	-	-
	Temperature sensor reading analysis	+	-	-	-
	Verification of set parameters of the frequency converter	-	-	-	+
	Verification of the temperature sensor readings	+	-	-	-
	Operation checking of the frequency converter of the rotor drive	-	-	-	+
	Operation checking of protective circuit	-	+	-	-
	<b>Water heater:</b>				
	Visual inspection	-	-	+	-
4.	Cleaning and washing	-	-	-	+
	Operation check-up of the 3-way heat medium control valve (if the system is filled with heat medium) and the circulation pump	-	-	+	-
	<b>Electric heater:</b>				
	Visual inspection	-	+	-	-
5.	Cleaning	-	-	+	-
	Check-up of the electric heating elements	-	-	+	-
	<b>Water cooler:</b>				
	Visual inspection	-	+	-	-
6.	Cleaning (together with the droplet separator)	-	-	-	+
	<b>DX cooler:</b>				
	Visual inspection	-	+	-	-
7.	Cleaning (together with the droplet separator)	-	-	-	+
	<b>Cross-flow heat exchanger:</b>				
	Visual inspection	-	+	-	-
	Check-up of the drain pan	-	+	-	-
8.	Check-up of the drain system and U-trap	-	+	-	-
	Check-up of the bypass damper and damper actuator	-	+	-	-
	Heat exchanger cleaning	-	-	-	+
	<b>Rotary heat exchanger:</b>				
	Check-up of the rotor smooth rotation	-	+	-	-
9.	Check-up of the belt condition and tightening	-	+	-	-
	<b>Exhaust/Supply air shutters:</b>				
	Check-up of the shutters smooth operation	-	-	+	-
10.	Checking of the electric actuator and electric connections	-	-	+	-
	Damper cleaning	-	-	+	-
	<b>Back airflow damper with shutters:</b>				
	Checking air shutters for smooth operation	-	-	+	-
11.	Checking of the electric actuator and electric connections	-	-	+	-
	Damper cleaning	-	-	+	-
	<b>Supply and extract fans:</b>				
	Visual inspection and check-up of the electric motors and impellers	-	+	-	-
	Check-up of the motor fixation and vibration dampers on the mounting frame in the fan section	-	+	-	-
	Check-up of the terminal connections in the motor terminal box	-	-	+	-
12.	Checking of the impeller fixation to the motor shaft	-	-	+	-
	Checking of the indirect motor heating temperature under the rated operation conditions	-	-	+	-
	Current checking and measuring for each phase	-	-	-	+
	Verification of the frequency converter parameters	-	-	-	+
	Cleaning of the impeller and motor from dust	-	-	+	+

(!) — more intensive contamination requires more frequent applications.

\*— filter cleaning and replacement frequency may vary depending on the region and air pollution degree.



## ALARMS

	Alarm	Alarm source	Possible troubles
1.	Fire signalling	External signal from the fire alarm system. External signal from the fire alarm system. The inputs of the external terminals are closed and the alarm signal is generated.	Check the inlet circuits.
2.	Supply fan	Operation signal from the supply fan frequency converter.	Check the frequency converter settings. Check the parameters of the controller inputs. These parameters must be consistent with the frequency converter parameters.
		Fan pressostat.	Check the fan operation. Check the pressostat operation. Check the thermostat capillary tube mounting.
3.	Extract fan	Operating signal of the extract fan frequency converter.	Check the frequency converter settings. Check the parameters of the controller inputs. These parameters must be consistent with the frequency converter parameters.
4.	Temperature sensor	Malfunction of any temperature sensor.	Check the current temperature readings in the controller menu, see «Current status». If the controller reads the temperature -40 °C, it indicates a short circuit in the corresponding sensor circuit. If the controller reads the temperature +150 °C, it indicates a circuit breakdown.
5.	Heat exchanger freezing	This malfunction occurs if the temperature drops below the set point over a specified time.	Check the parameters of the control low for the heat exchanger.
			Check the actuating device for operability.
			Check the exhaust air temperature for operability.
6.	Rotary heat exchanger	Operation signal from the rotary heat exchanger frequency converter.	Check the frequency converter settings. Check the parameters of the controller inputs. These parameters must be consistent with the frequency converter parameters.
7.	Heater freezing	Tripping of the freeze protection thermostat of the heater. The freeze protection function is activated also in the summer mode.	Set the thermostat tripping temperature from 8 to 10 °C. Check the thermostat control circuit. Check the settings of the operating contact for compliance.
8.	Low water temperature	Low heat medium temperature at the end of the heating cycle.	Check the heat medium. Check the pump. Check operation of the actuating device. Check heat medium flow.
9.	Low return heat medium temperature	Low heat medium temperature during operation.	Check the heat medium temperature. Check operation of the circulation pump. Check operation of the actuating device. Check heat medium flow and make sure the hydraulic system is not clogged.
10.	Circulation pump	No pump operation control.	Check the pump operability. Check operability of the control unit (pressostat, flow rate sensor, etc.). If a control unit is not available, jump the respective inputs.
11.	Supply filter	Supply filter clogging.	Check for clogging. Check the clogging control device (pressostat).
12.	Extract filter	Extract filter clogging.	Check for clogging. Check the clogging control device (pressostat).
13.	Heater overheating	Tripping of the overheating thermostat.	Check the supply air damper for opening, check the supply filter for clogging, check operability of the actuating device (relay).
14.	Low supply air temperature	Low supply air temperature within 10 minutes (scheduled) is interpreted as underheating.	Check the heating element and control circuit condition. Make sure that the environmental conditions of the installation place match the stated conditions.

## TROUBLESHOOTING

	Problem	Possible source	Troubleshooting method
1.	Low air flow.	Filter clogging.	Clean the filter using a vacuum cleaner against air flow direction or install a new filter. (!) Do not wash the filter with water or detergents!
		Malfunction of the pressostat or breakdown of the commutation circuit (NC - normally closed contact).	Check the status of the pressostat or check its circuit (NC - normally closed contact).
2.	Low air flow.	Filter clogging, heater or heat exchanger contamination.	Clean the fan, the heater and the heat exchanger.
		Fan malfunction.	Check power supply to the fan. Check the control system for errors.
		One or two air dampers are closed.	Check the air damper for smooth opening. Check connection to power supply and available control signal on the damper actuator.
		Wrong rotation direction of the fan.	Check the three-phase motor for correct phase sequence. Check the capacitor capacity and its status for the single-phase motor. Check the software settings and the rotation direction. <b>(!) The rotation direction is shown on the impeller of the ventilation unit.</b>
3.	Water dripping in the unit.	Drain line clogging.	Clean the pipes.
		No U-trap.	Install the U-trap.
		Wrong unit-drain line mounting angle.	Check the installation angle of the air handling unit/drain line for consistence with the data stated in the technical documentation. Correct it if required.
4.	No heating (applicable for the air handling units with an integrated heater).	No power supply to the electric heating elements.	Check power supply to the heater section. Check resistance of each heating element and check them for integrity. In case of any breach on the circuit of the heating element replace it.
		Tripping of the thermal switch TK 90 °C.	Press the button «Reset» on the thermal switch TK90 for manual reset. (!) Troubleshoot the tripping source for TK90.
		No contact on the electric heating elements.	Press the connection lugs of the heating elements.
		Breaking of the electric heater element (wire breaking).	Replace the electric heating element.
		Breakdown of the solid-state relay.	Check the condition of the solid-state relay using a volt-ohm meter. Normally the relay does not acts as a conductor and is closed.
5.	Water heater/cooler has insufficient heating or cooling capacity.	No heat medium.	Check availability of the heat medium in the hydraulic system, its temperature and pressure.
		Air locks in the hydraulic system.	Deaerate the system.
		No heat medium circulation.	Check power supply to the circulation pump. Check the pump rotor for rotation.
		Malfunction or closing of the mixing unit.	Check that the power is supplied to the mixing unit drive.
			Check that the drive is correctly connected to the actuating device.
		The bypass damper is open.	Check the bypass drive for jamming and correct connection. Check that the bypass has been opened in accordance with the control system's algorithm.
6.	Abnormal noise generated by the unit.	Direct connection of the air duct to the casing without anti-vibration connector.	Do not allow the air duct to be connected directly to the unit.
		Motor bearing wear.	Check rotation of the rotor with idle running. Noise and skirr may indicate the run-out of the bearing service life. Measure the phase current and compare it with the data sheet.
		The fan is rotating in the wrong direction.	Check the software settings and the rotation direction. <b>(!) The rotation direction is shown on the impeller of the ventilation unit.</b>
7.	Malfunction of one or two motors.	No power supply to the electric motors.	Check the voltage.
		Motor winding breakdown or turn-to-turn short circuit of the motor winding.	Use a multimeter to measure the resistance of each motor windings.
		No control signal for EC motors.	Make sure the signal is available for specified status of the control system parameters. Check the control system for errors.

	<b>Problem</b>	<b>Possible source</b>	<b>Troubleshooting method</b>
8.	Generation of condensate in inappropriate places in the unit.	Air motion inside of the unit during standstill caused by air draughts because of open dampers or no dampers.	Check that the supply and exhaust dampers are in good condition.
		Internal air leakages as a result of severe clogging of one or two filters.	Clean the filter using a vacuum cleaner against air flow direction or install a new filter. (!) Do not wash the filter with water or detergents!
		Inappropriate use of the air handling unit.	Check the transported air parameters (humidity + temperature) and the environmental parameters.

## CONTROL MEASUREMENTS OF OPERATING PARAMETERS

The technical maintenance of the unit includes routine measurements of the following parameters:

- Correct temperature and humidity of the processed air both upstream and downstream of the air handling unit.
- The operating parameters of the components in the connected heating and cooling equipment.
- Proper operation of the electrical equipment (power consumption measurements).
- Proper operation of the fan groups specific to maintaining the air flow and unit operation parameters.

All the work specific to the routine control measurements and technical maintenance operations must be confirmed with the appropriate documents.

## STORAGE AND TRANSPORTATION RULES



**ATTENTION!**  
**TRANSPORTATION AND HANDLING OPERATIONS**  
**MUST BE APPROACHED WITH CAUTION!**

The unit is delivered to the site either fully assembled or in sections to undergo final assembly immediately on the site (depending on the complexity of the installation configuration or the customer's requirements).

The blocks must not be piled vertically. Any mechanical damage which may be caused by vertical piling shall not be covered under the manufacturer's warranty.

Depending on the standard size and weight of the unit (all the necessary information being given on the specification sheets on the unit) a variety of special transport devices can be used for loading and unloading operations such as a hoisting crane, a lifting beam or a forklift. The holes in the unit base enable loading and unloading operations by means of a hoist crane.

The side protection of the units is provided by the buffer beams of appropriate length depending on the unit size.

The unit can also be loaded and unloaded by means of a lifting beam. In any case the side panels must be protected against accidental damage by the forklift or cables.

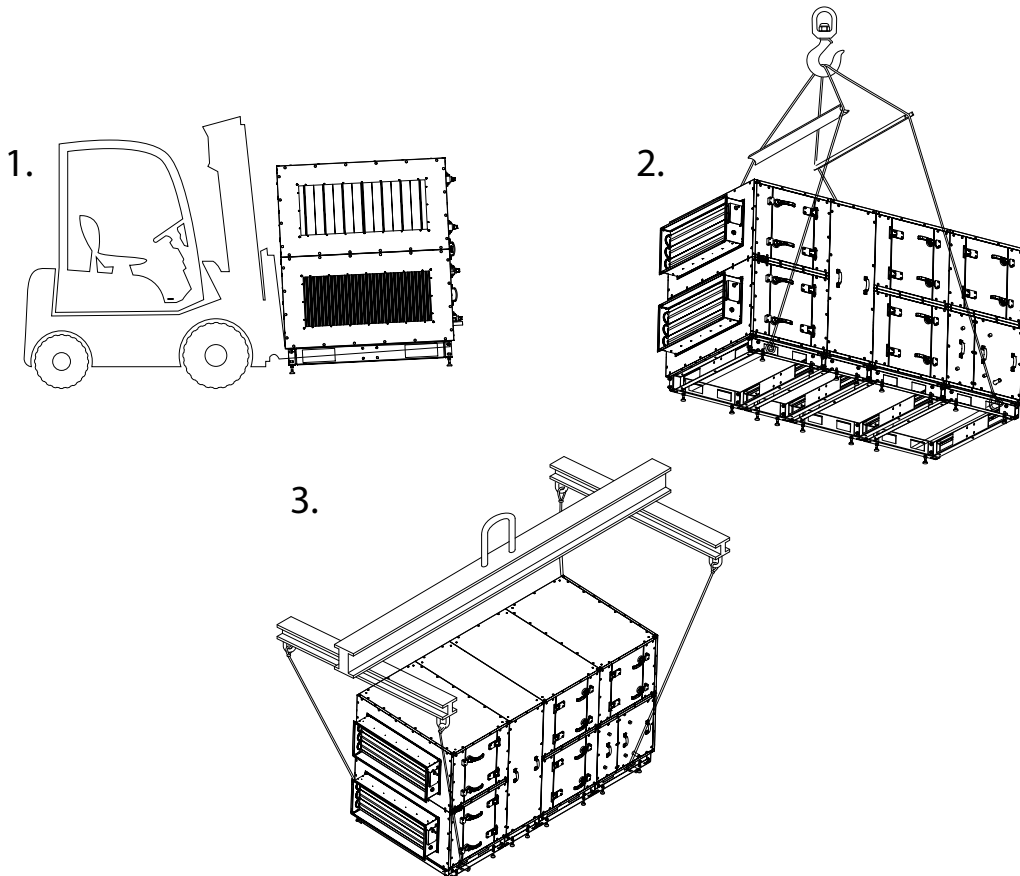

**THE ROTARY HEAT EXCHANGER SECTIONS MUST BE TRANSPORTED WITH EXTREME CARE SO AS TO PREVENT AN ACCIDENTAL DAMAGE TO THE ROTARY HEAT EXCHANGER.**

Upon delivery to the destination site check the unit for damage and the completeness of the accompanying documents. The space intended for unit storage must meet the following basic requirements:

- Protection against atmospheric precipitation;
- Dry conditions with air temperatures from  $-20\text{ °C}$  ...  $+30\text{ °C}$ ;
- Absence of aggressive environments, gases or dust which may lead to corrosion of the unit or its components.

The manufacturer's warranty does not cover any mechanical damage to the unit resulting from improper transportation, handling or storage.

## MANUFACTURER'S WARRANTY

The product is in compliance with EU norms and standards on low voltage guidelines and electromagnetic compatibility. We hereby declare that the product complies with the provisions of Electromagnetic Compatibility (EMC) Directive 2014/30/EU of the European Parliament and of the Council, Low Voltage Directive (LVD) 2014/35/EU of the European Parliament and of the Council and CE-marking Council Directive 93/68/EEC. This certificate is issued following test carried out on samples of the product referred to above.

The manufacturer hereby warrants normal operation of the unit for 36 months after the retail sale date provided the user's observance of the transportation, storage, installation, and operation regulations. Should any malfunctions occur in the course of the unit operation through the Manufacturer's fault during the guaranteed period of operation, the user is entitled to get all the faults eliminated by the manufacturer by means of warranty repair at the factory free of charge. The warranty repair includes work specific to elimination of faults in the unit operation to ensure its intended use by the user within the guaranteed period of operation. The faults are eliminated by means of replacement or repair of the unit components or a specific part of such unit component.

### The warranty repair does not include:

- routine technical maintenance
- unit installation/dismantling
- unit setup

To benefit from warranty repair, the user must provide the unit, the user's manual with the purchase date stamp, and the payment paperwork certifying the purchase. The unit model must comply with the one stated in the user's manual. Contact the Seller for warranty service.

### The manufacturer's warranty does not apply to the following cases:

- User's failure to submit the unit with the entire delivery package as stated in the user's manual including submission with missing component parts previously dismantled by the user.
- Mismatch of the unit model and the brand name with the information stated on the unit packaging and in the user's manual.
- User's failure to ensure timely technical maintenance of the unit.
- External damage to the unit casing (excluding external modifications as required for installation) and internal components caused by the user.
- Redesign or engineering changes to the unit.
- Replacement and use of any assemblies, parts and components not approved by the manufacturer.
- Unit misuse.
- Violation of the unit installation regulations by the user.
- Violation of the unit control regulations by the user.
- Unit connection to power mains with a voltage different from the one stated in the user's manual.
- Unit breakdown due to voltage surges in power mains.
- Discretionary repair of the unit by the user.
- Unit repair by any persons without the manufacturer's authorization.
- Expiration of the unit warranty period.
- Violation of the unit transportation regulations by the user.
- Violation of the unit storage regulations by the user.
- Wrongful actions against the unit committed by third parties.
- Unit breakdown due to circumstances of insuperable force (fire, flood, earthquake, war, hostilities of any kind, blockades).
- Missing seals if provided by the user's manual.
- Failure to submit the user's manual with the unit purchase date stamp.
- Missing payment paperwork certifying the unit purchase.



**FOLLOWING THE REGULATIONS STIPULATED HEREIN WILL ENSURE A LONG AND TROUBLE-FREE OPERATION OF THE UNIT**



**USER'S WARRANTY CLAIMS SHALL BE SUBJECT TO REVIEW ONLY UPON PRESENTATION OF THE UNIT, THE PAYMENT DOCUMENT AND THE USER'S MANUAL WITH THE PURCHASE DATE STAMP**

UNIT COMPONENTS	
Name	Number
Extract fan	
Supply fan	
Air filter	
Water heater	
Electric heater	
Water cooler	
DX cooler	
Plate heat exchanger	
Rotary heat exchanger	
Humidifier	
Dehumidifier	
Silencer	
Air damper	
Air damper with electric actuator	
Flexible connector	
AUTOMATION UNIT	
<b>Other</b>	

**Sticker**

### CERTIFICATE OF ACCEPTANCE

<b>Unit Type</b>	Heat recovery air handling unit
<b>Model</b>	
<b>Serial Number</b>	
<b>Manufacture Date</b>	
<b>Quality Inspector's Stamp</b>	

### SELLER INFORMATION

<b>Seller</b>	
<b>Address</b>	
<b>Phone Number</b>	
<b>E-mail</b>	
<b>Purchase Date</b>	
This is to certify acceptance of the complete unit delivery with the user's manual. The warranty terms are acknowledged and accepted.	
<b>Customer's Signature</b>	

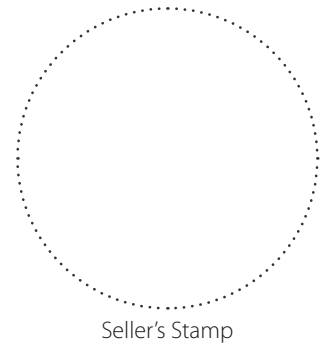

### INSTALLATION CERTIFICATE

The _____ unit is installed pursuant to the requirements stated in the present user's manual.	
<b>Company name</b>	
<b>Address</b>	
<b>Phone Number</b>	
<b>Installation Technician's Full Name</b>	
<b>Installation Date:</b>	<b>Signature:</b>
The unit has been installed in accordance with the provisions of all the applicable local and national construction, electrical and technical codes and standards. The unit operates normally as intended by the manufacturer.	
<b>Signature:</b>	

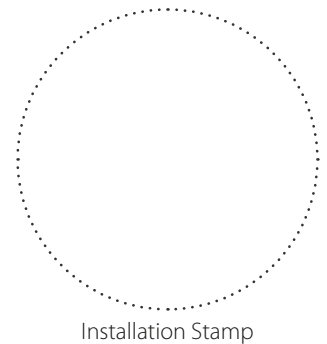

### WARRANTY CARD

<b>Unit Type</b>	Heat recovery air handling unit
<b>Model</b>	
<b>Serial Number</b>	
<b>Manufacture Date</b>	
<b>Purchase Date</b>	
<b>Warranty Period</b>	
<b>Seller</b>	

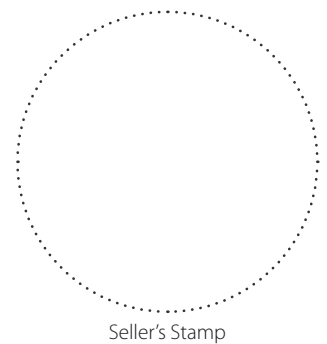



**VENTS**

